

Product Technical Bulletin **SPS-3H**

BITUMEN-POLYMER WATERPROOFING MEMBRANE, MADE FROM SELECT SBS AND DISTILLED BITUMEN, REINFORCED WITH SPUNBOND POLYESTER FABRIC.

BITEC SPS-3H is a hot asphalt applied, smooth surfaced, modified bitumen waterproofing membrane composed of carefully selected asphalts (bitumen) having superior modifying characteristics, blended with high quality styrene-butadiene-styrene rubber. SPS-3H is reinforced with spunbond polyester fabric. SPS-3H waterproofing membrane yields the following performance characteristics:

- ★ Impermeable to water
- ★ Low temp flexibility
- ★ Thermally stable
- ★ Excellent adhesion
- ★ Resistant to acids and most bases
- ★ Puncture resistant
- ★ Excellent workability
- ★ Longevity

Spunbond polyester fabric, used as a reinforcement in SPS-3H has isotropic mechanical properties giving the composite membrane similar mechanical characteristics in all angular directions in relation to the membrane surface. Spunbond polyester fabric imparts the following properties to the composite membrane:

- ★ High flexibility
- ★ Puncture resistance
- ★ High elongation
- ★ Mechanical strength
- ★ Fatigue resistance
- ★ Tear strength
- ★ Deterioration resistance
- ★ Dimensional stability

SPS-3H incorporates a smooth and even application of fine sand to prevent blocking of rolls and to provide a smooth, acceptable application surface. SPS-3H can be applied by using hot asphalt or any BITEC APPROVED ELASTOMERIC COLD PROCESS ADHESIVE. (When using cold adhesives, follow the specific adhesive manufacturer's installation specifications.)

After installation of the roofing membrane is complete, the surface must be coated with an APPROVED BITEC ROOF COATING to protect the membrane from the harmful effects of ultra violet radiation and for U.L. fire rating if required. BITEC recommends that a period of at least 45 days elapse before the roof coatings are applied. This will effectively allow the membrane to "cure" and accept the roof coating.

PACKAGING

Palletized units contain 24 rolls of SPS-3H waterproofing membrane. Each unit is shrink wrapped in a special polyethylene bag for stability. BITEC recommends that units of material be single stacked.

SPS-3H has no mineral surface, and therefore must be coated by a BITEC APPROVED COATING, or receive a flood coating of ASTM D312 roofing asphalt with roofing gravel applied at a minimum rate of 400 lb./sq.

SPS-3H can be used as either a cap sheet, an interply, or a base sheet. The overall roofing system performance will be enhanced by its use as a base sheet.



APPLICATION

Depending on the type of roof, SPS-3H can be either fully adhered, spot or partially adhered, or loose laid. BITEC specifications applicable to this product should be consulted to determine which system should be employed. When applying the membrane, the fine sand surface should always be down facing the roof deck. Prior to application, the membrane should be unrolled completely, aligned, allowed to relax and set before the actual installation of the membrane occurs. The membrane should then be rolled up half way, leaving the other half fully extended. (This will insure that the membrane will remain aligned during the installation process.)

SPS-3H is designed to be applied by conventional methods of hot mopping, using ASTM D312 TYPE III mopping asphalt. ASTM TYPE IV should be used on slopes greater than 3" in 12". The Roofing Contractor shall not let the mopping asphalt temperature fall below 450°F, or overheat the asphalt to overcome rapid cooling. BITEC recommends that mopping asphalt EVT requirements be met when heating asphalt. Mopping of base and cap sheet plies shall be done at a rate of 25 lbs./100 ft. sq. in a solid mopping of hot asphalt. It is essential that the asphalt be applied uniformly at a distance not to exceed 4' in front of the advancing roll surface. A continuous, 1/4" bead of uninterrupted mopping asphalt shall be seen coming from the end and side laps. Seams which are not fully bonded can be repaired by inserting a hot trowel between the affected seam and lightly torching. Upon removal of the hot trowel, pressure should be applied to the top ply, forcing the

modified bitumen to flow out the desired distance.

All side and end laps should be a minimum of 3" and 6" respectively.

If the membrane is loose laid, an area of 40" each side of the end lap should be fully bonded to the roof surface.

BITEC SBS HOT APPLIED MEMBRANES CAN BE INSTALLED IN HOT ROOFING ASPHALT OR IN BITEC APPROVED COLD PROCESS ADHESIVES.

BITEC SBS MEMBRANES ARE NOT RECOMMENDED FOR USE OVER COAL TAR OR PITCH ROOFS UNLESS THE EXISTING DECK IS SEPARATED FROM THE BITEC MEMBRANE BY A MINIMUM 1/2" THICK, MECHANICALLY ATTACHED RECOVER BOARD. BITEC DOES NOT ALLOW THE USE OF PLASTIC ROOFER'S CEMENT WITH ANY OF ITS MEMBRANES.

AS WITH ANY ROOFING PROJECT, GOOD ROOFING PRACTICES SHOULD ALWAYS BE FOLLOWED. CONSULT THE BITEC SPECIFICATION AND DETAILS BOOK FOR INFORMATION GOVERNING CERTAIN SYSTEMS.

TOOLS REQUIRED

To apply BITEC SPS-3H waterproofing membrane, the only tools needed are: a roofer's kettle, lug bucket, roofer's mop, dial thermometer, spatula or round nose roofer's trowel, a roofer's knife, pair of work gloves, flat soled shoes and an ABC dry chemical fire extinguisher at the kettle and on the roof.

BEFORE USING THIS PRODUCT, BE CERTAIN THAT ALL INFORMATION CONCERNING THE INSTALLATION OF THIS PRODUCT AND SAFETY GUIDELINES PERTAINING THERETO HAVE BEEN READ AND FULLY UNDERSTOOD. THE APPLICATION OF MODIFIED MEMBRANES REQUIRES THE USE OF EXPLOSIVE GAS AND

MOLTEN ASPHALTS, WHICH IF MISHANDLED CAN AND WILL CAUSE PERSONAL INJURY AND/OR PROPERTY DAMAGE.

SAFETY

THE CONTRACTOR

It is the contractor's responsibility to observe all fire prevention policies and practices, to train, instruct and warn employees on the use of torching equipment. Follow OSHA and NRCA provisions for fire protection, including but not limited to those listed in OSHA 1910.151, 155, 156, 157, and 1910.1101, which apply to torch application. The contractor should be familiar with NFPA 58 "Standard for the Storage and Handling of Liquefied Petroleum Gas" and any other appropriate publications of the National LP Gas Association.

FIRE DEPARTMENT REGULATIONS

The contractor should be familiar with all local fire codes in his area. The contractor is responsible for obtaining all necessary permits or certificates before any work is started.

PERSONNEL

Proper clothing should be worn at all times while installing any modified membrane. Long sleeve shirt, long pants, leather or durable flat soled shoes and work gloves.

THE ROOFING CONTRACTOR AND HIS EMPLOYEES ARE THE KEY TO SUCCESS REGARDING SAFETY...

SAFETY SHOULD ALWAYS BE FIRST!

SPECIFICATION:
SPS-3H.1
NON-NAILABLE DECK

If plans or specifications require installation of a modified bitumen membrane system over a non-nailable deck apply this specification (SPS-3H.1).

Apply this system using the appropriate BITEC approved base flashing, metal flashing or wall covering as specified in the most current edition of the BITEC "Roofing Material Specification and Details" publication.

SEC. 1.00 INSULATION

The following insulations are acceptable for use with SPS-3H:

- PERLITE
- GLASS FIBER
- POLYISOCYANURATE
- WOOD FIBER
- CELLULAR GLASS

SEC. 2.00 CANTS

Flashing details, where the transition is from the horizontal to a vertical surface, a non-combustible cant strip must be used.

SEC. 3.00 BASE SHEET

A minimum of one ply of fiberglass TYPE G2 base sheet must be installed over the insulation or deck before the membrane is applied.

SEC. 4.00 FASTENERS

Consult Factory Mutual Research Publications governing your geographical region, or FM J.I.OG3A3.AM governing BITEC products and systems.

SEC. 5.00 OUTLETS

Drainage outlets shall be installed below the roof deck surface to permit POSITIVE DRAINAGE of the roof deck and

to prevent water ponding at the drain rim. Base ply should be evenly trimmed with the drain flange, followed with a 40" x 40" hot-applied collar of BITEC SPS-3H. This collar must extend into and be fully adhered to the interior of the drain flange and interior surface. The SPS-3H membrane shall be fully adhered to the base ply, SPS-3H flashing collar and extend into the drain. Clamp ring should be installed and tightened while the membrane is hot. A 4 lb. lead or 16 oz. copper flashing is required between the collar and the SPS-3H field membrane. SPS-3H collar should extend 4" beyond the lead or copper flashing.

SEC. 6.00 PIPE FLASHING

Where penetrations occur in the roof surface a collar of SPS-3H should be installed over the base ply extending a minimum of 4" beyond the flanges. A metal flashing shall be installed having a continuous flange 4" minimum, on top of the SPS-3H collar. (On nailable decks, the metal flange must be nailed 3" o.c., 3/4" from the perimeter.)

ALL METAL FLASHINGS MUST BE PRIMED WITH AN ASPHALT PRIMER AND ALLOWED TO DRY BEFORE MEMBRANE AND FLASHINGS ARE INSTALLED.

The SPS-3H field membrane must be fully adhered to the SPS-3H collar and metal flange. All seams must be troweled and filled with molten modified bitumen or hot asphalt.

SEC. 7.00 ROOF DECK

The roof deck must be smooth, dry, clean and free of sharp projections and depressions, and properly graded to outlets.

THE ROOFING CONTRACTOR, ARCHITECT, AND THE ENGINEER MUST ALLOW FOR POSITIVE DRAINAGE WHEN DESIGNING THE ROOF DECK OR ROOF SYSTEM. BITEC DEFINES POSITIVE DRAINAGE

AS: ROOF DECK BECOMES DEVOID OF WATER WITHIN 72 HOURS AFTER LIQUID PRECIPITATION HAS OCCURRED. BITEC WILL NOT BE RESPONSIBLE FOR MEMBRANE DAMAGE AS A RESULT OF INADEQUATE ROOF DECK DRAINAGE.

SEC. 8.00 FINAL SURFACING

A BITEC APPROVED ROOF COATING must be applied to the finished membrane system.

BITEC RECOMMENDS THAT A PERIOD OF AT LEAST 45 DAYS ELAPSE BEFORE ROOF COATING IS APPLIED. (ROOF COATING MAY BE NECESSARY TO COMPLY WITH U.L. OR F.M. SYSTEM REQUIREMENTS.)

BITEC WILL NOT COVER MEMBRANE DAMAGE OR FAILURE OF ANY ROOF SYSTEM, RESULTING FROM COATINGS FROM ANOTHER MANUFACTURER.

******* WARRANTIES *******

BITEC, INC.

offers two warranties:

(1) 10-YR. MATERIAL ONLY

(2) 10-YR. LIMITED "INSURED" ROOFING WARRANTY*

In order to obtain warranty (2), which covers labor and materials, an AUTHORIZED BITEC APPLICATOR must install the roofing system. A small warranty fee is assessed if the system is not coated or does not have a factory installed mineral surface. Final inspection by a BITEC FIELD REPRESENTATIVE is necessary before issuance of warranty. Information regarding BITEC warranties may be obtained from: MANAGER OF TECHNICAL SERVICES by calling 800-535-8597.

*Extended warranty periods are available, 12, 15 and 20 years.

NOTE: It is recommended that product be stored away from direct sun light and indoors until immediately before use.

SPECIFICATION:
SPS-3H.2
NAAILABLE DECK

If plans or specifications require installation of a modified bitumen membrane system over a nailable deck apply this specification (SPS-3H.2).

Apply this system using the appropriate BITEC approved base flashing, metal flashing or wall covering as specified in the most current edition of the BITEC "Roofing Material Specification and Details" publication.

SEC. 1.00 INSULATION

The following insulations are acceptable for use with SPS-3H:

- PERLITE
- GLASS FIBER
- POLYISOCYANURATE
- WOOD FIBER
- CELLULAR GLASS

SEC. 2.00 CANTS

Flashing details, where the transition is from the horizontal to the vertical surface, a non-combustible cant strip must be used.

SEC. 3.00 BASE SHEET

A minimum of one ply of fiberglass TYPE G2 base sheet must be installed over the insulation or deck before the membrane is heat welded.

SEC. 4.00 FASTENERS

Consult Factory Mutual Research Publications governing your geographical region, or F.M. J.I.OQ3A3.AM governing BITEC products and systems.

SEC. 5.00 OUTLETS

Drainage outlets shall be installed below the roof deck surface to permit POSITIVE DRAINAGE of the roof deck and

to prevent water ponding at rim. Base ply should be evenly trimmed with the drain flange, followed with a 40" x 40" hot applied collar of BITEC SPS-3H. This collar must extend into and be fully adhered to the interior of the drain flange and interior surface. The SPS-3H membrane shall be fully adhered to the base ply, SPS-3H flashing collar and extend into the drain. Clamp ring shall be installed while the membrane is still hot. A 4 lb. lead or 16 oz. copper flashing is required between the collar and the SPS-3H field membrane. SPS-3H collar should extend 4" beyond the lead or copper flashing.

SEC. 6.00 PIPE FLASHING

Where penetrations occur in the roof surface a collar of SPS-3H should be installed over the base ply extending a minimum 4" beyond the flanges. A metal flashing shall be installed having a continuous flange 4" minimum on top of the SPS-3H collar. (On nailable decks, the metal flange must be nailed 3" o.c., $\frac{3}{4}$ " from the perimeter.)

ALL METAL FLASHINGS MUST BE PRIMED WITH AN ASPHALT PRIMER AND ALLOWED TO DRY BEFORE MEMBRANE AND FLASHINGS ARE INSTALLED.

The SPS-3H field membrane must be fully adhered to the SPS-3H collar and metal flange. All seams must be troweled and filled with molten modified bitumen or hot asphalt.

SEC. 7.00 ROOF DECK

The roof deck must be smooth, dry, clean and free of sharp projections and depressions, and properly graded to outlets.

THE ROOFING CONTRACTOR, ARCHITECT, AND THE ENGINEER MUST ALLOW FOR POSITIVE DRAINAGE WHEN DESIGNING THE ROOF DECK OR ROOF SYSTEM. BITEC DEFINES POSITIVE DRAINAGE

AS: ROOF DECK BECOMES DEVOID OF WATER WITHIN 72 HOURS AFTER LIQUID PRECIPITATION HAS OCCURRED. BITEC WILL NOT BE RESPONSIBLE FOR MEMBRANE DAMAGE AS A RESULT OF INADEQUATE ROOF DECK DRAINAGE.

SEC 8.00 FINAL SURFACING

A BITEC APPROVED ROOF COATING must be applied to the finished membrane system.

BITEC RECOMMENDS THAT A PERIOD OF AT LEAST 45 DAYS ELAPSE BEFORE ROOF COATING IS APPLIED. (ROOF COATING MAY BE NECESSARY TO COMPLY WITH U.L. OR F.M. SYSTEM REQUIREMENTS.)

BITEC WILL NOT COVER MEMBRANE DAMAGE OR FAILURE OF ANY ROOF SYSTEM, RESULTING FROM COATINGS FROM ANOTHER MANUFACTURER.

******* WARRANTIES *******

BITEC, INC.

offers two warranties:

(1) 10-YR. MATERIAL ONLY

(2) 10-YR. LIMITED "INSURED" ROOFING WARRANTY*

In order to obtain warranty (2), which covers labor and materials, an AUTHORIZED BITEC APPLICATOR must install the roofing system. A small warranty fee is assessed if the system is not coated or does not have a factory installed mineral surface. Final inspection by a BITEC FIELD REPRESENTATIVE is necessary before issuance of warranty. Information regarding BITEC warranties may be obtained from: MANAGER OF TECHNICAL SERVICES by calling 800-535-8597.

*Extended warranty periods are available, 12, 15 and 20 years.

NOTE: It is recommended that product be stored away from direct sun light and indoors until immediately before use.

TECHNICAL SCHEDULE

**SPS-3H ROLLS ARE 1 METER WIDE AND 33.5 FEET IN LENGTH.
FLASHING ROLLS ARE AVAILABLE IN HALF AND QUARTER WIDTHS.**

APPROVALS	UL (R13231)	
SOFTENING POINT (ASTM D-36)	250°F (120°C)	
REINFORCEMENT	Trevira polyester fabric	
PENETRATION (ASTM D5)	40 dmm @ 25°C	
SLIDE (UNI-8202)	<1 mm	
COLD FLEXIBILITY (UNI-8202)	passed -13°F (-25°C)	
WATER TIGHTNESS (CGSB 37-GP-56M)	passed	
DYNAMIC PUNCTURE (CGSB 37-GP-56M)	passed	
STATIC PUNCTURE (CGSB 37-GP-56M)	passed	
TENSILE STRENGTH (ASTM D-412)	MD = 105 lbf/in	XMD = 75 lbf/in
ELONGATION (ASTM D412)	MD = 60%	XMD = 70%
LOAD STRAIN PRODUCT (CGSB 37-GP-56M)	MD = 56,048 n	XMD = 46,706 n
THICKNESS	3 mm	
ROLL WEIGHT, APPROX.	73 lbs	
COVERAGE, INSTALLED APPROX.	100 ft ²	
TOTAL SURFACE AREA, APPROX.	109.9 ft ²	

All Information is given in good faith, but normal tolerances of manufacture and testing will apply. BITEC reserves the right to improve and change its products at any time without prior notice or advice. The use of BITEC products is determined by local conditions and indi-

vidual requirements of each contract. In consideration of the many factors involved, BITEC cannot be held responsible for the application of its products and for conditions beyond its control. All claims filed against BITEC warranties will be subject to the provisions set forth

at the date of warranty issuance, and any addendums thereto. Under no circumstances will BITEC be held liable for any damage, whether personal injury or property damage, which occur during or after the application of the membrane.

For more information concerning this and other fine BITEC products,

CALL 1-800-535-8597

Ask for Manager, Technical Services

PARAPET WALL DETAIL

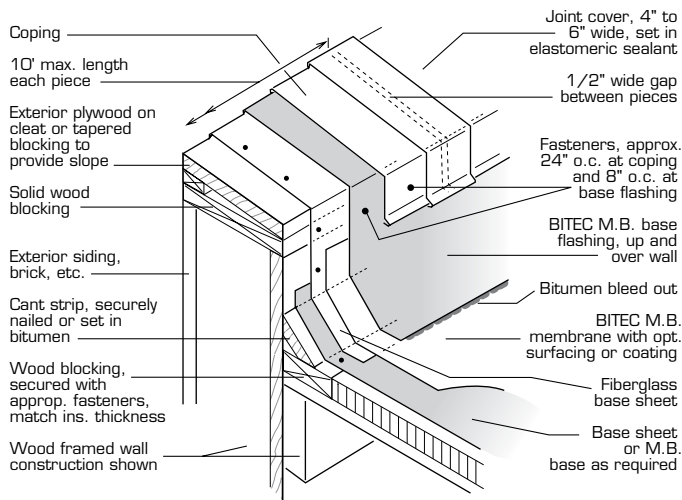

EDGE DETAIL

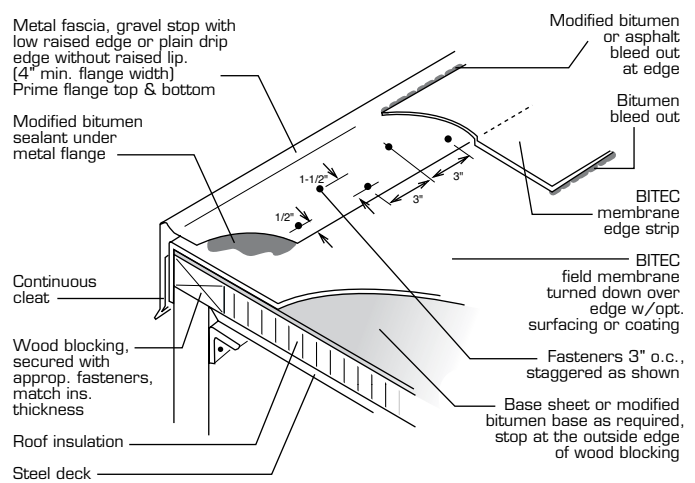

ROOF DRAIN DETAIL

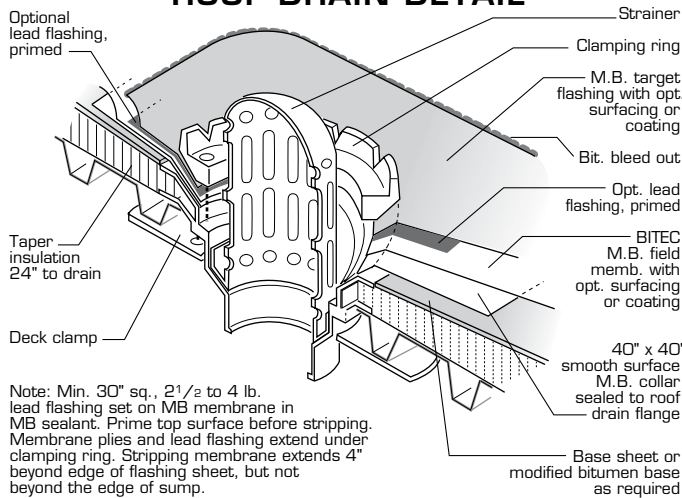

VENT PIPE DETAIL

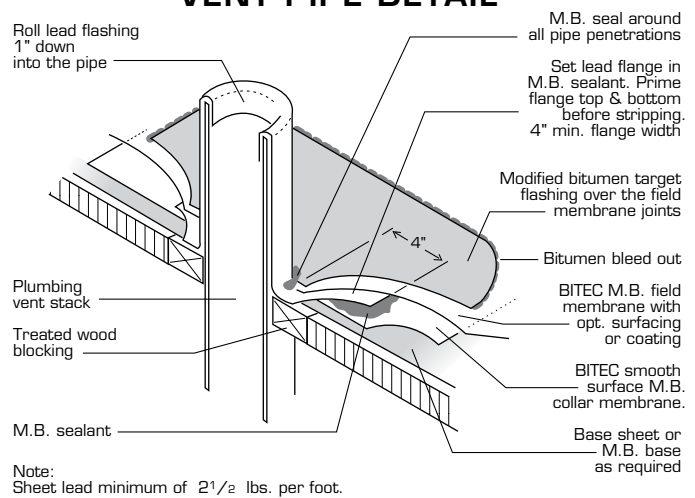

DISTRIBUTED BY:

APPROVALS:



Membrane for Roofing Systems
Classified By
Underwriters Laboratories, Inc.
As to an external fire exposure only
49S8

R-13231

MEMBER OF:



BITEC

BITUMEN TECHNOLOGY™

Visit our web site at www.bi-tec.com

MANUFACTURERS OF ADVANCED TECHNOLOGY WATERPROOFING MEMBRANES

P.O. Box 497 • No. 2 Industrial Park Drive • Morrilton, Arkansas 72110 • Fax (501) 354-3019 • Phone 1-800-535-8597