

## **PRODUCT TECHNICAL BULLETIN**

# **COMPABASE PS-2H**

## **AN SBS MODIFIED BITUMEN BASE SHEET MEMBRANE, REINFORCED WITH SPUNBOND SPUNBOND POLYESTER FABRIC**

Compabase PS-2H is composed of select distilled bitumen and SBS; reinforced with spunbond polyester fabric. Compabase PS-2H will eliminate the concerns of compatibility and performance between SBS cap sheets bonded to oxidized bitumen base sheets by heat welding. Compabase PS-2H also enhances the overall flexibility and fatigue resistance of hot applied systems.

Compabase PS-2H also eliminates the concern that the oxidized bitumen component of the roof system is the "weak link" in performance. Oxidized bitumen base sheets are not modified with SBS polymer. These base sheets are hard, brittle and have poor flexibility at lower temperatures in comparison

to modified bitumen base sheets. Oxidized bitumen does not blend well with SBS polymer.

Compabase PS-2H, when used in conjunction with any BITEC SBS modi-

fied bitumen membrane, will give you a membrane system unsurpassed in performance.

BITEC'S Compabase PS-2H, used in lieu of oxidized bitumen base sheets and applied with modified SBS cap sheets, will turn your one-ply modified bitumen roofing membrane system into a two-ply modified bitumen roofing system with excellent performance characteristics.

### **ADVANTAGES OF USING COMPABASE**

- ★ System compatibility
- ★ Two-ply modified bitumen system
- ★ Excellent flexibility
- ★ Excellent weatherability
- ★ Easy to apply
- ★ Good dimensional stability
- ★ Enhances modified bitumen system performance
- ★ Keeps your BITEC modified bitumen membrane system in total performance



## APPLICATION

Compabase PS-2H is applied by using ASTM TYPE III or TYPE IV roofing asphalt, or by mechanical attachment. Compabase PS-2H shall be installed having 3" and 4" minimum side and end laps, respectively.

Compabase PS-2H may be installed using BITEC APPROVED ELASTOMERIC ADHESIVES. (Projects requiring labor and mate-

rial warranty must have prior approval from BITEC's Manager of Technical Services if elastomeric adhesives are to be used.)

## STORAGE AND HANDLING

Compabase PS-2H is shipped in palletized, shrink wrapped units of 24 rolls per unit. Rolls should be stored under cover away from direct exposure to the elements until immediately before use. If it becomes

necessary to store material on the job site or roof deck, units should be covered with an opaque tarpaulin or similar cover. (Clear or black protective coverings are not acceptable.)

Units should also be elevated from the roof deck by placement upon a pallet. If possible, material should be stored away from direct sunlight during storage at the job site. Do not stack units two or more high.

## TECHNICAL SCHEDULE

MODIFIER	SBS	
APPROX. ROLL SIZE	49.2 ft x 3.28 ft	
SEAM WIDTH	3"	
APPROX. COVERAGE	150 ft <sup>2</sup>	
TOP SURFACE	sand	
BOTTOM SURFACE	sand	
NOMINAL THICKNESS	2 mm	
NOMINAL WEIGHT	70 lb.	
REINFORCEMENT	spunbond polyester	
SOFTENING POINT (ASTM D-360)	240°F (116°C)	
COLD FLEXIBILITY (UNI-8202)	14°F (-10°C)	
TENSILE STRENGTH (ASTM D-412)	105 lbf/in (MD)	80 lbf/in (XMD)
ELONGATION (ASTM D-412)	50% (MD)	50% (XMD)

## LAYING PATTERN FOR MECHANICALLY ATTACHED BASE SHEET

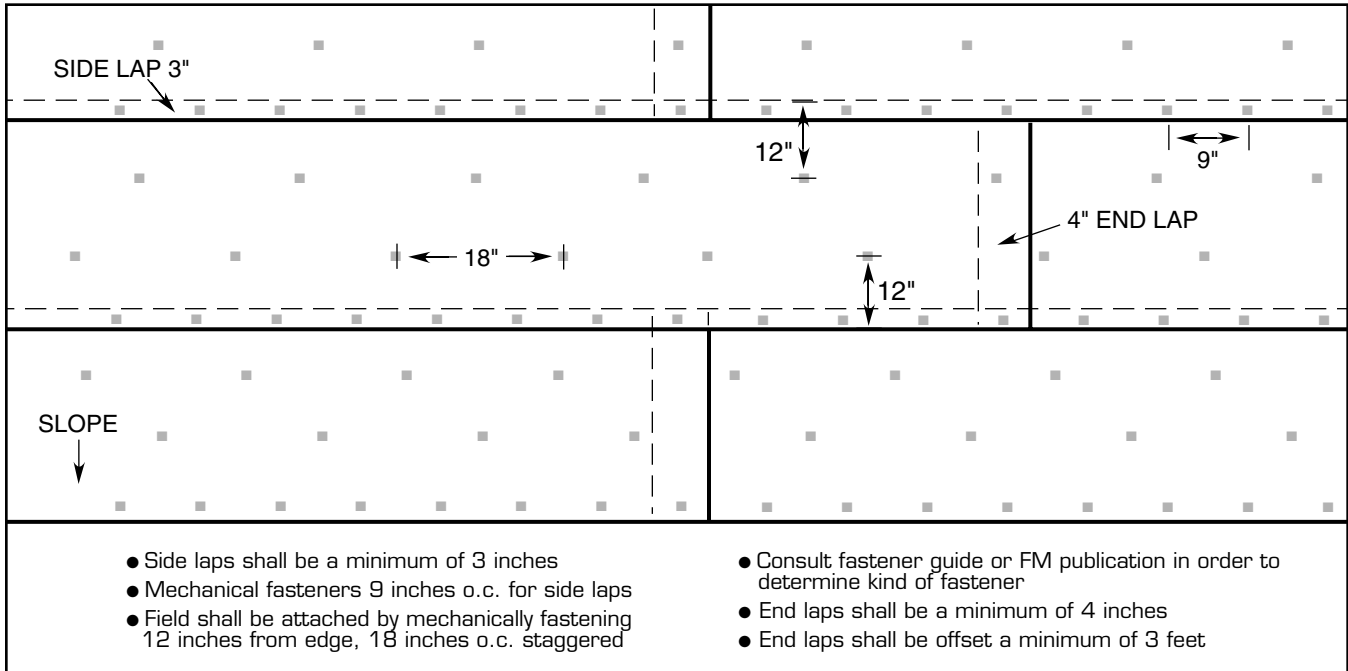

## LAYING PATTERN FOR HOT MOPPED BASE SHEET

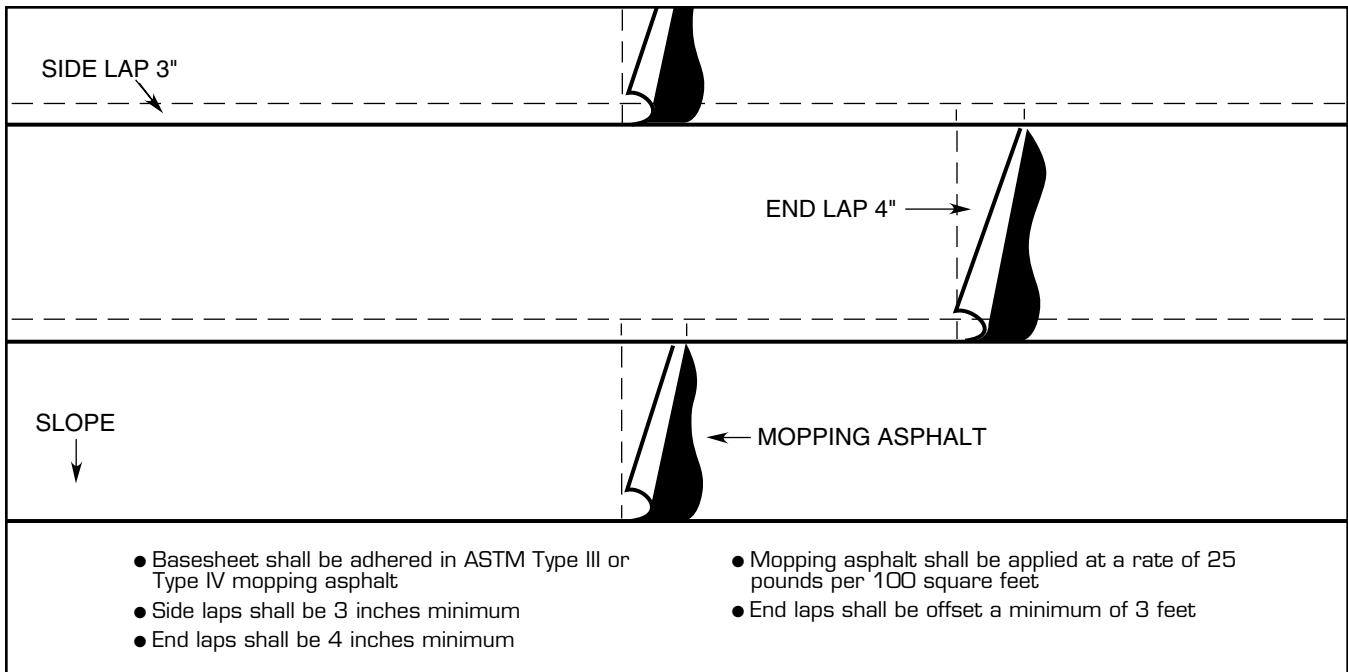

For more information concerning this and other fine BITEC products,

**CALL 1-800-535-8597**

Ask for Manager, Technical Services

## PARAPET WALL DETAIL

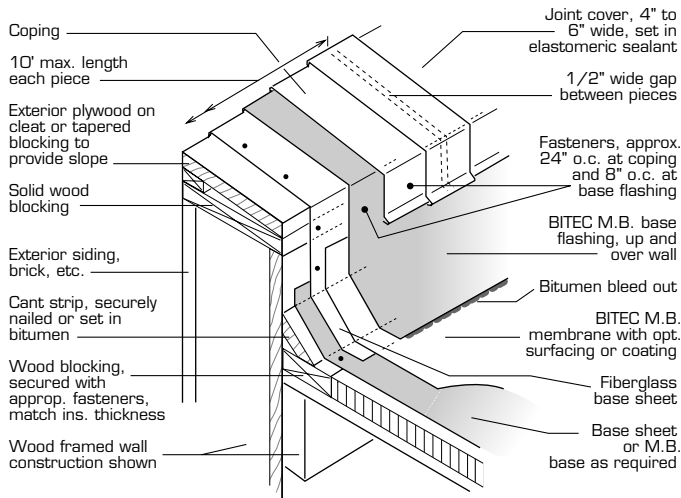

## EDGE DETAIL

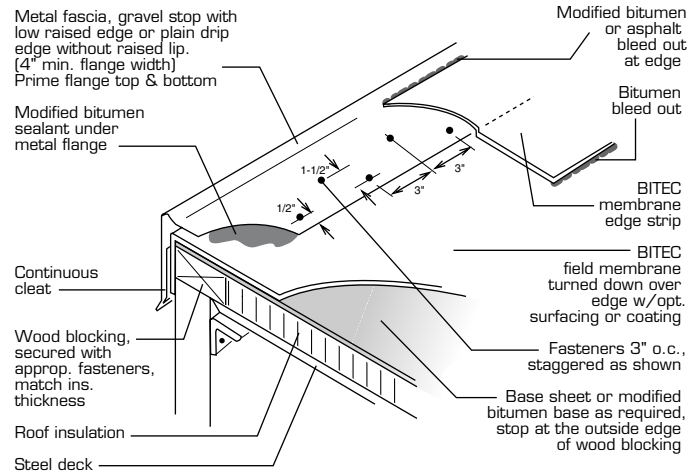

## ROOF DRAIN DETAIL

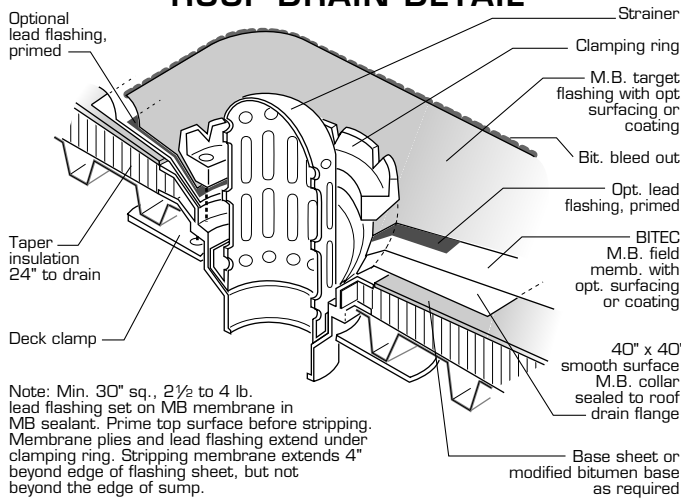

## VENT PIPE DETAIL

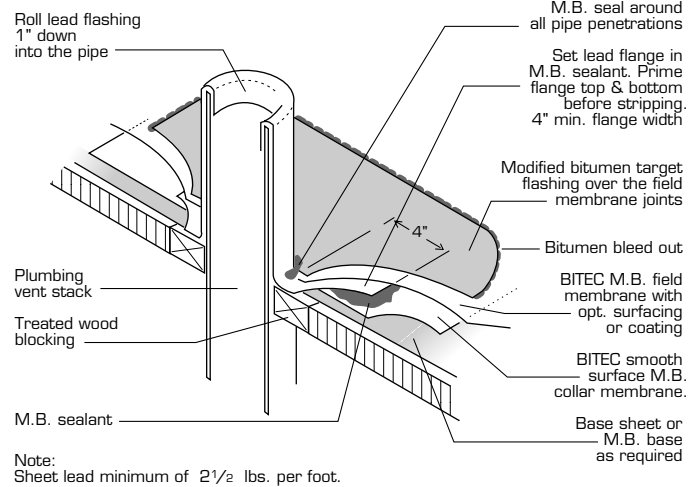

DISTRIBUTED BY:

APPROVALS:

MEMBER OF:



Type G2 Coated Cap or Base/Ply Sheet For Roofing Systems Underwriter's Laboratories, Inc. As to an external fire exposure only 49S8



# BITEC

BITUMEN TECHNOLOGY™

Visit our web site at [www.bi-tec.com](http://www.bi-tec.com)

**MANUFACTURERS OF ADVANCED TECHNOLOGY WATERPROOFING MEMBRANES**

P.O. Box 497 • No. 2 Industrial Park Drive • Morrilton, Arkansas 72110 • Fax (501) 354-3019 • Phone 1-800-535-8597